

Echo 30™ Jets

Specifications

Seating Capacity	7 Adults	
Dimensions	78" x 78" x 36" (198 cm x 198 cm x 91 cm);	
Perimeter	312 in. (714.7 cm)	
Dry Weight	414 lbs (187 kg)	
Filled Weight (Spa Volume)	4,117 lbs (1,867 kg)	
Filled Weight (Average Fill)	3,150 lbs (1,429 kg)	
Water Capacity (Spa Volume) ...	444 US gallons (1,681 Liters)	
Water Capacity (Average Fill) ...	328 US gallons (1,242 Liters)	
Electronic Controls	Digital Touch Controller. Offers customizing of cleaning cycles and water temperature setting.	
Pump 1	North America (60 Hz): 2-Speed, 2.0 HPR	
Export (50 Hz):	2 kW, 2-Speed	
Pump 2	N/A	
Export (50 Hz):	N/A	
Circulation Pump	N/A	
Total Jets	30	
Seat A Jets	4 DirectionalMax1 Jets, 2 DirectionalMax2 Jets	
Seat B Jets	2 DirectionalMax1 Jets	
Seat C Jets	8 DirectionalMax2 Jets	
Seat D Jets	6 DirectionalMax2 Jets	
Seat E Jets	2 DirectionalMax1 Jets	
Seat F Jets	4 DirectionalMax1 Jets, 2 DirectionalMax2 Jets	
Massage Selectors	N/A	
Air Controls	2	
Water Management System	One Easy Kleen 30 ft ² filter cartridge; Optional factory installed Ozone	
Export (50 Hz):	Optional factory installed Ozone	
LED Lighting	Multicolor waterfall light; Exterior corner light (white color only)	
Shell/Cabinet Colors	Mystic Sparkle, Tuscan Sparkle, Night Sparkle, Glacier Sparkle	
Headrests	4	
Waterfalls	One with independent flow rate (on or off) adjustment; powered by pump 1	
Heater:	Hi Flow 1.0kW/4kW	
Export (50 Hz):	Hi Flow 3.0kW	
Electrical Requirements:	North America (60 Hz): Convertible 120 VAC@15A	
	Export (50 Hz): 230-240V@1x16A, 1X32A	
Warranty*	North America (60 Hz): 5 Years Shell, 5 Years Shell Surface, 1 Year Plumbing Component Leaks, 1 Year Equipment and Controls, 1 Year Cabinet, 1 Year Jets, 1 Year Lights;	
	Export (50 Hz): 5 Years Shell, 5 Years Shell Surface, 2 Years Plumbing Component Leaks, 2 Years Equipment and Controls, 2 Years Cabinet, 2 Years Jets, 2 Years Lights;	
Special Features	N/A	

*(See Warranty Document for Specific Details)

Dimensions/Specifications are Subject to Change Without Notice

Echo 30 Jets

Operation/Seat Depths



- Ⓐ Topside Control - Activate Jet Pump, Light and Control Water Temperature
 - Ⓑ Water Feature Control - Controls Water Feature Output.
 - Ⓒ Air Control - Activates Seat A Jets (4 DirectionalMax1 Jets, 2 DirectionalMax2 Jets), Seat B Jets (2 DirectionalMax1 Jets), Seat C Jets (8 DirectionalMax2 Jets)
 - Ⓓ Air Control - Activates Seat D Jets (6 DirectionalMax2 Jets), Seat E Jets (2 DirectionalMax1 Jets), Seat F Jets (4 DirectionalMax1 Jets, 2 DirectionalMax2 Jets)
- Jet Pump 1: All seats and footwell jets

30 Total Jets

DirectionalMax1
Jets (12)

DirectionalMax2
Jets (18)



Spa Operation Subject to Change without Notice

- A = 26.50" (67.30 cm)
- B = 24.75" (62.86 cm)
- C = 28.00" (71.12 cm)
- D = 28.00" (71.12 cm)
- E = 24.75" (62.86 cm)
- F = 26.50" (67.30 cm)
- G = 20.00" (50.80 cm)
- H = 34.50" (87.63 cm)

Seat Depths

Listed dimensions represent distance from top of spa to lowest point in seat.
Tolerance: ± 0.5" (1.27 cm)



Dimensions/Specifications are Subject to Change Without Notice

Echo 30 Jets

Dimensions

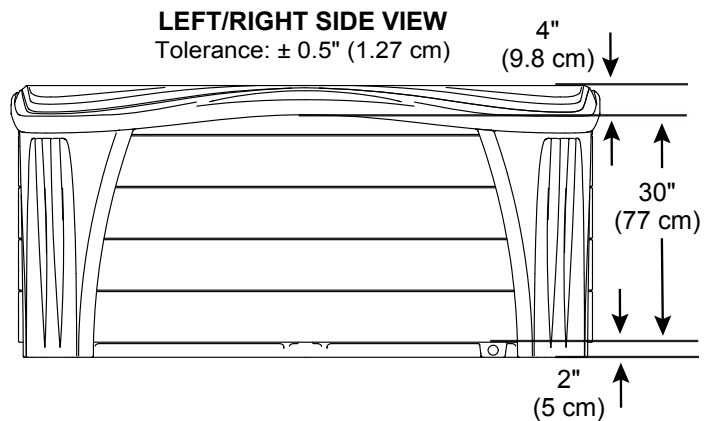
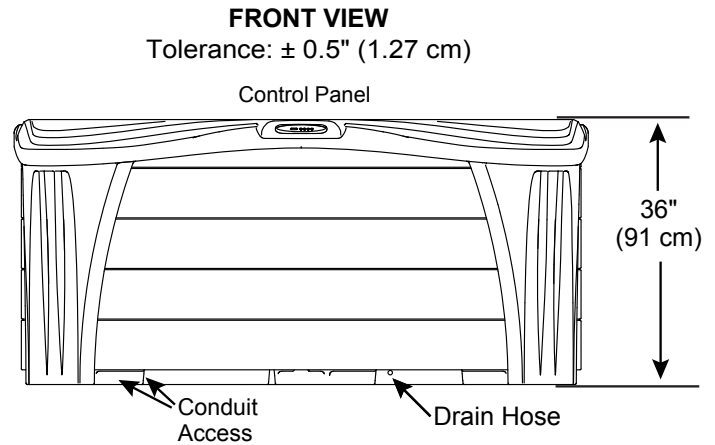
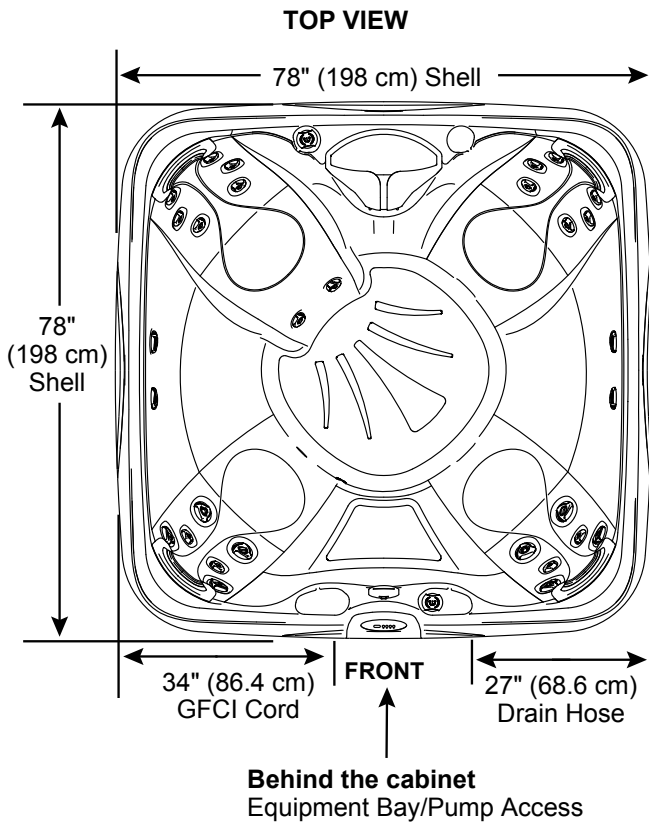

IMPORTANT! Always measure each hot tub for exact dimensions BEFORE designing its foundational support and/or decking.

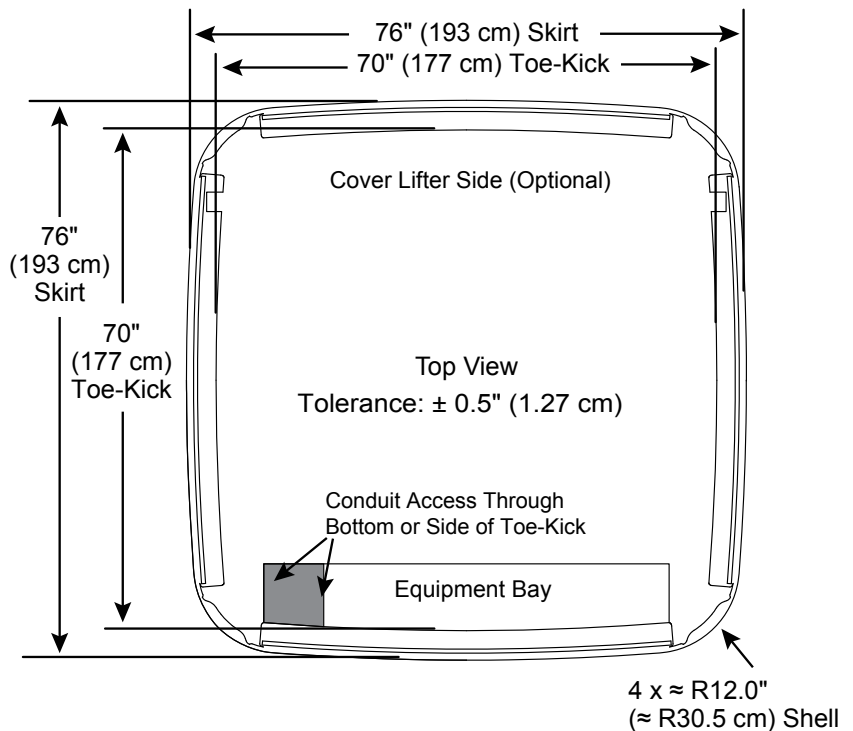

Dimensions/specifications subject to change without notice. Tolerance $\pm 0.5"$ (1.27 cm)